

ITEM	QTY.	DESCRIPTION	MATERIAL	NOTES
1	1	BOLT	3/4-16 STEEL ZINC-PLATE	
2	2	DOWEL PIN .156 x .50	STEEL	
3	1	NUT	3/4-16 STEEL ZINC-PLATE	
4	1	BHCS 2-56 x .188	ALLOY STEEL	
5	1	BAR	.250 X .375 LOW CARBON STEEL	
6	1	DRAWING PIN	MAKE FROM .156 x .50 DOWEL PIN	

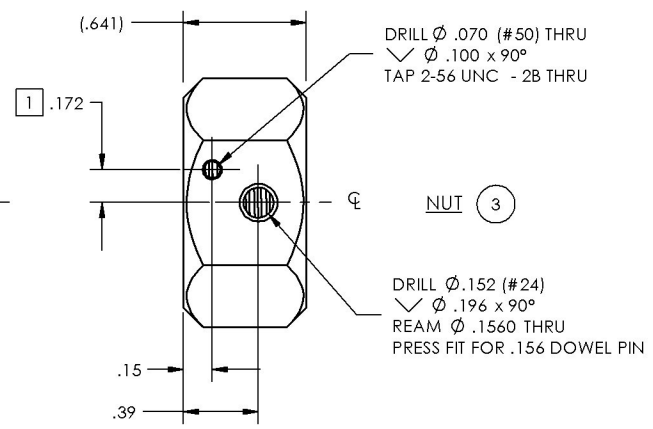
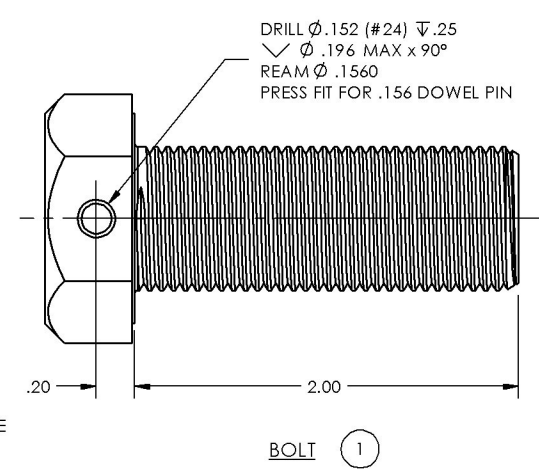
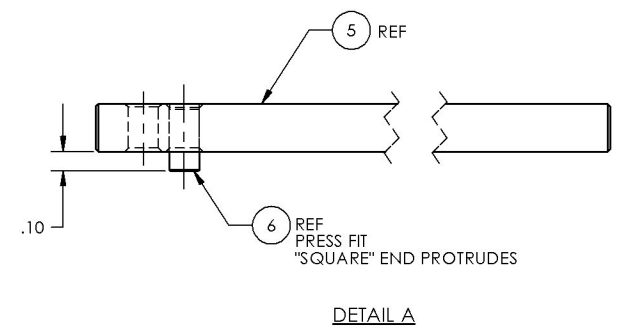
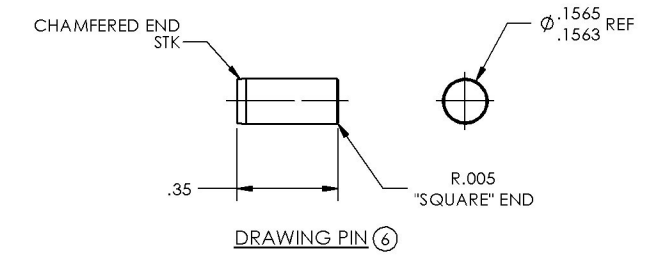
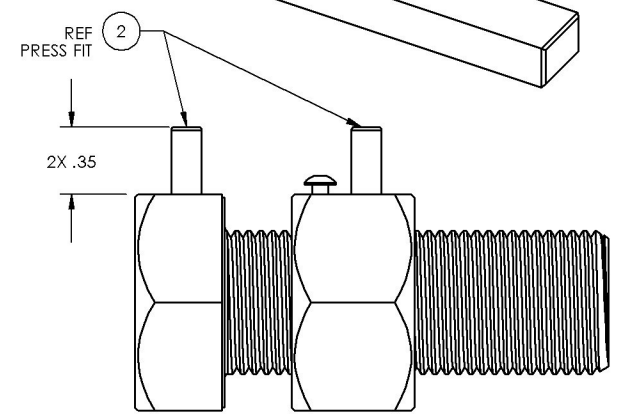
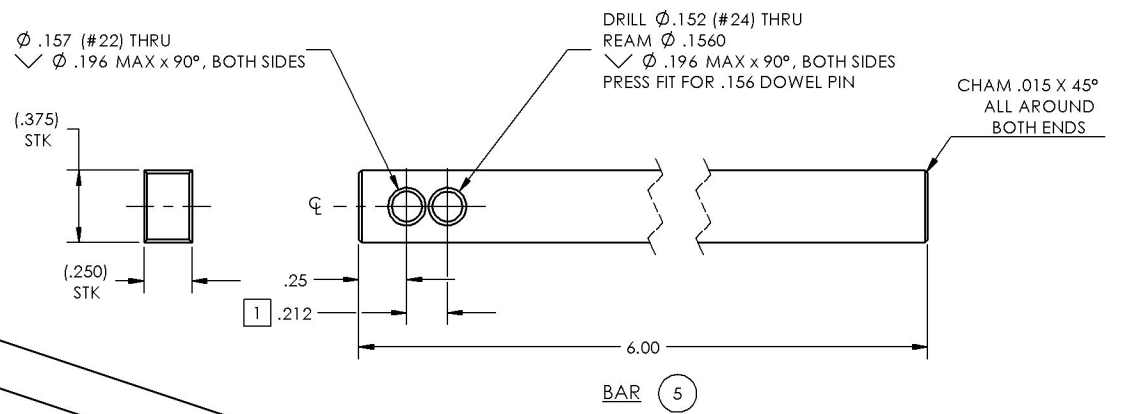
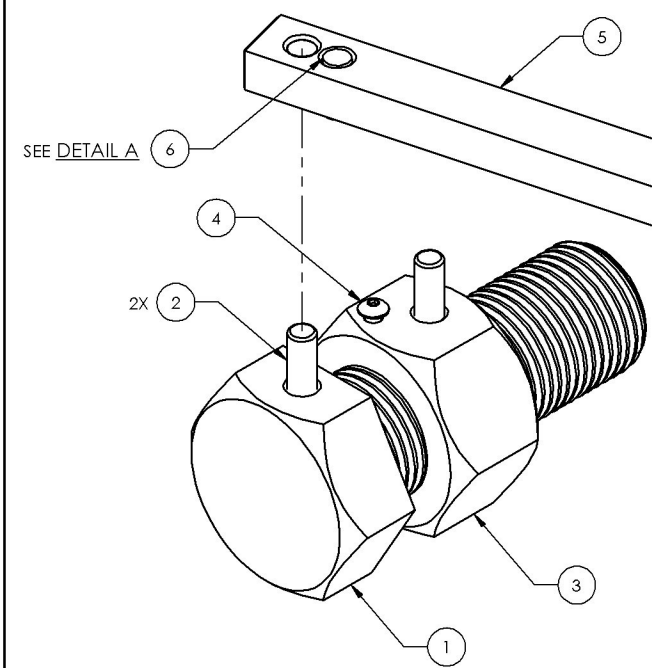

NOTES:
 1. DIMENSIONS INDICATED ARE FOR FORMING ϕ .051 WIRE. INCREASE OR DECREASE CORRESPONDINGLY FOR LARGER OR SMALLER WIRE.